



Advanced Wheelend Technologies

Service bulletin

Slack adjuster to cam-spline assembly requirements

This procedure is strongly recommended to ensure proper protection of the splines on the camshaft as well as those in the slack adjuster. It prevents oxygen as well as the road contaminants from entering the air gap of the spline assembly, thus reducing considerably oxidation and premature wear of assembly, while keeping the parts easy to disassemble.

Parts description

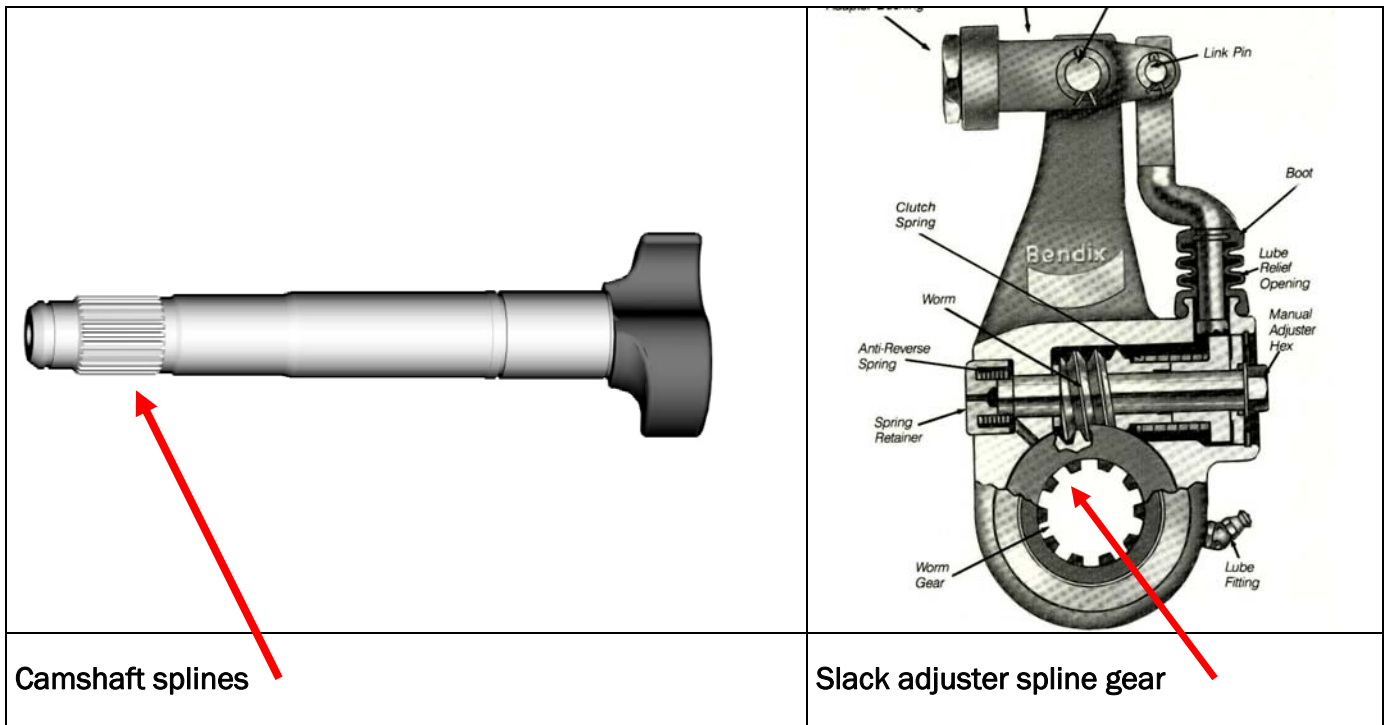

To succeed with this procedure, the technician must complete the assembly of all brake components, including wheel hubs and drums before attempting to install the slack adjusters onto the camshafts.

Camshafts have to be installed and properly shimmed and lubrication of the center bracket bushing should wait after the slack adjusters are installed and the spline sealing agent is properly set.

Remember that the "OPTIMUM-CONTACT" system is designed to outlast the life of the trailer, so we must think ahead to stay ahead.

Assembly procedure

Always wear adequate protective gear in accordance to the environment in which you evolve and pertinent to the tasks accomplished. Always follow safety procedures.

	Step 1; Clean the splines of the camshaft and the slack adjuster with brake cleaner or other proper solvent, and dry off with compressed air.
	Step 2; Introduce lubricant to the Automatic Brake Adjusters until splined gear is well lubricated on either sides of the unit's casing. Wipe off excess lubricant and make sure splines are still dry and lube free.
	Step3; Apply a sufficient amount of High Temp RTV silicone or Thread locking agent onto the splines of the camshaft and those of the slack adjuster, and assemble both parts together, wiping the excess sealant to prevent seizing the slack adjuster.
	Step 4; Lock the adjuster in place with the proper snap-rings and shims.
	Step 5; Crank the slack adjuster to apply the brake shoes firmly to the brake drum to engage the splines of both components tightly, and let the High Temp RTV silicone or Thread locking agent set as specified by its manufacturer. One could apply the parking brake to achieve similar results.
	Step 6; Once the High Temp RTV silicone or Thread locking agent has cured, release and readjust the brakes within specifications.

NOTE: **High Temp RTV silicone** is usually sufficient to achieve good results. **Thread locking agent** is used when Silicone fails to keep it's integrity and breaks off, and in heavy-duty and / or off-road applications. **USE ONLY LOW STRENGHT Thread locking agent IF FORCED TO DO SO.**

Repeat steps 1 through 6 for each wheel.

Choose a good quality (low strength) Thread locking agent.

For any questions regarding this service bulletin please use our toll free tech support line;

1 - 877-765 -9629